



**Systems
Controls &
Instruments, L.L.C.**

R-3x4/4x5

Add a wire to installations

General Description:

Never been esier to ADD a WIRE to an installation.
With this simple and cost effective device, you can add the missing wire in an existing installation.
The best tool for retrofit jobs.
Usually the mechanical thermostats have 3 wires, to connect an Electronic thermostat you need 4 wires, this device will add the missing wire for you.

The Best Tool for Retrofit

Application:

This unit is the perfect solution for the installation of an electronic thermostat instead of a mechanical .
This device work with the SCI products as well as any other brand of thermostats.

Components:

1. Main board.
2. Convertor for a wire.

Main Board

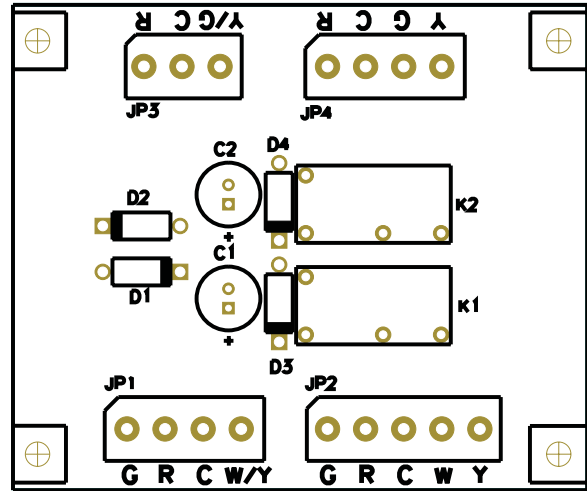

Convertor for a wire



We make life more comfortable!

Model:



R-3x4/4x5

Convert 3 wires into 5/ Convert 4 wires into 5 - 24Vac

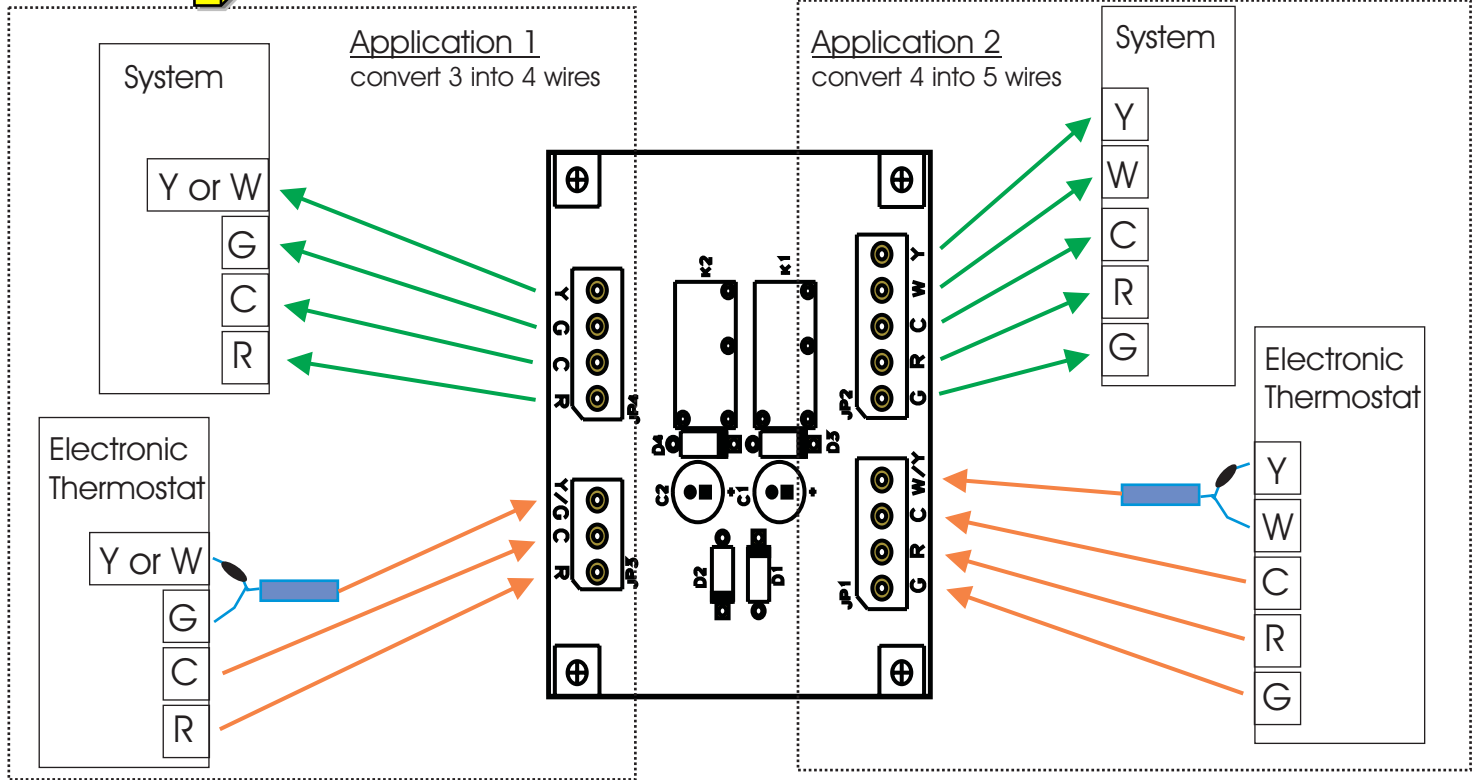
Typical applications



Legend :

- .Converter for a wire (included in the unit) 
- Existing wires in the wall 
- Wires to the System 

Black mark for connection

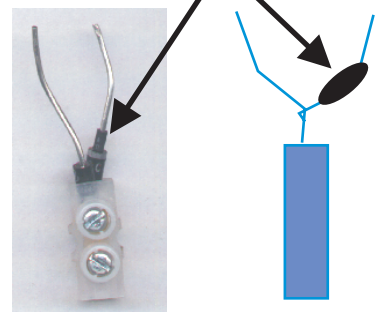

Systems
Controls &
Instruments, L.L.C.

Systems Controls & Instruments, L.L.C. 6140 Kit Road, Pipersville PA 18947 USA
Phone: (800) 663-8107 * Tel: (215)766-1487 Fax: (215) 766-1493
Email: info@scillc.com Web: www.scillc.com

We make life more comfortable!