

CEM - 24 Series

Owner's Manual - Installation and Operating Instructions

Please read this manual carefully before installation and use

Index :

1. Options
2. Accessories
3. Installation Instructions
4. Wiring Connections
5. Hardware Jumpers Explanation
6. Operating Manual
7. Programming
8. Fan/Auto Fan function
9. Override set temperature
10. Unoccupied Mode (set back mode)
11. Reset Button and Alarm Condition (red LED light)
12. Technician settings
13. Connection of External Sensor
14. To Replace Battery
15. Telephone settings
16. Menu of commands from a telephone to the thermostat
17. Troubleshooting for Technician

1. Options

- 1.1. Programmable or non-programmable: to Select, press one button and the program will remain in memory. (no need to reset it again)
- 1.2. External Temperature Sensor - (return air or wall mounted)
- 1.3. High and Low Temperature Alarm - Dry contact
- 1.4. Alarm for High and Low temperature is only indicated red LED
- 1.8. Scale in Fahrenheit or Celsius.
- 1.9. Individual cool and heat set points.
- 1.10 Fault indication from system (If connected)
- 1.11 Average Temperature sensing. Please look for details in our web site "Sensors & Accessories"

2. Accessories

- 2.1. Back Plate - 6"L x 4"W x 0.37"H - Part No. WP2.
- 2.2. Wide Back Plate - 6"L x 6"W x 0.37"H - Part No. WP3.
- 2.3. Temperature Sensor with 30 inches lead - Part No. TS01 .
- 2.4. Temperature Sensor in decorative box - Part No. RS01 .
- 2.5. Two temperature sensors in a decorative box (for averaging) - Part No. RS02 .
- 2.6. Duct temperature sensor - Part No. DT01.
- 2.7. Outdoor temperature sensor in sealed box - Part No. OT01

FOR DETAILS ON WHERE TO PURCHASE ACCESSORIES, PLEASE CONTACT SCI FOR YOUR NEAREST LOCATION OR VISIT OUR WEB SITE AT WWW.SCILLC.COM

3. Installation Instructions

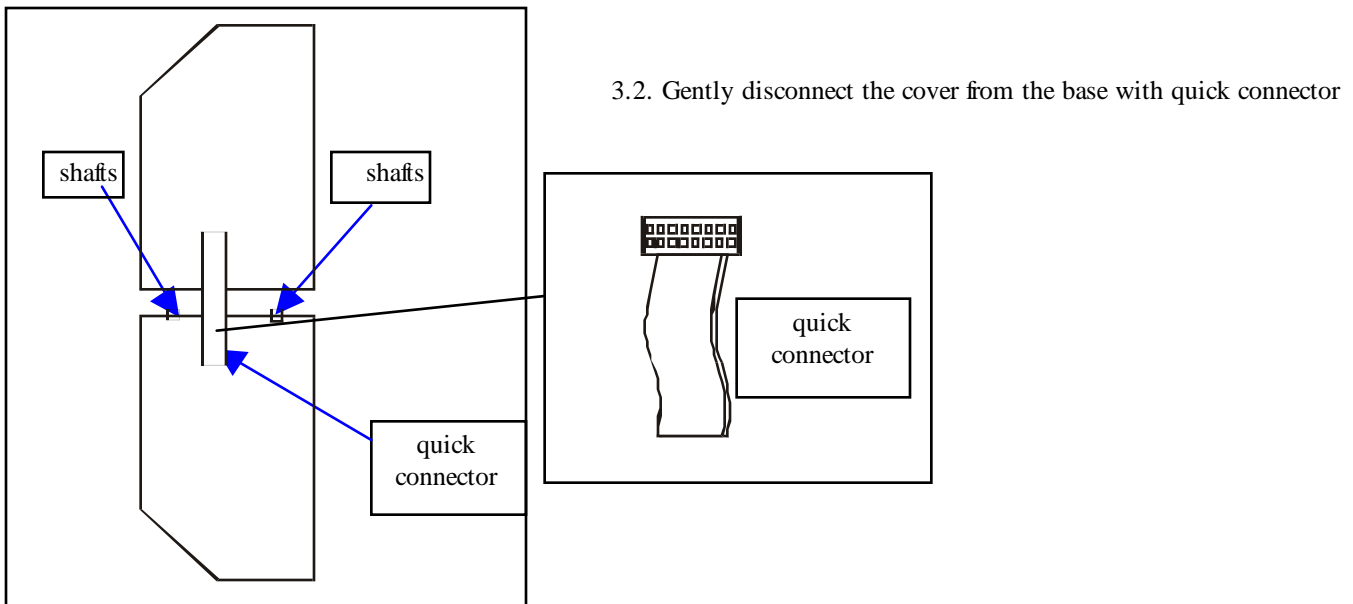
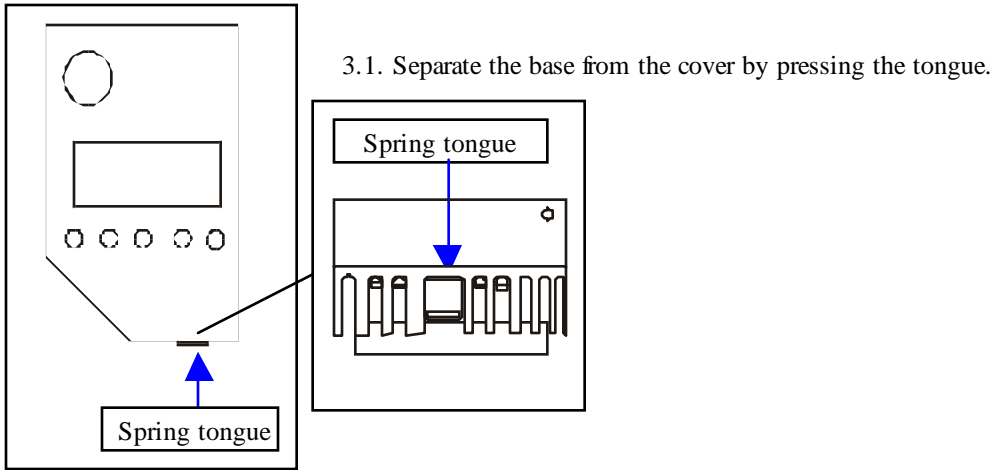

3.3 Line the back panel up against the wall or flat surface on which it is to be mounted and drill the appropriate fixing holes.

3.4. Insert screws so they extend approx. 3/16" (3 mm) from wall or surface.

3.5. Align the back panel against these screws, pushing it forward, allowing it to slide downwards to lock into position.

3.6. Make electrical connections to terminals on the back panel as shown on enclosed electrical wiring diagram

3.7. Reconnect the quick connector.

3.8. Adopt the cover to the base, first the two shafts and then the spring.

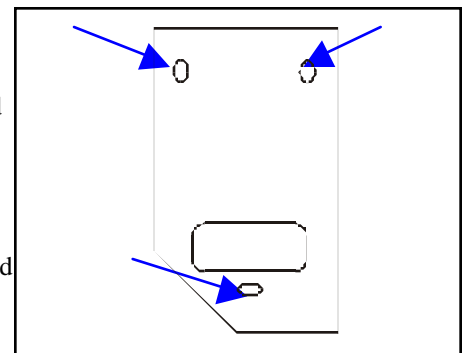

3.9. Connect 24Vac to the thermostat, verify that LCD display is ON . (DO NOT ENTER BATTERY BEFORE THAT)

3.10. Remove battery from back panel by sliding it to the left and out from its white retaining clip and mount it in black holder on front panel; insert it from the top, gently pressing downwards until it snaps into place and is held under the top clip of the holder.

BE CAREFUL WHEN INSERTING THE BATTERY, THE TOP CLIP OF THE HOLDER IS VERY FRAGILE.

The + engraved on battery should be visible

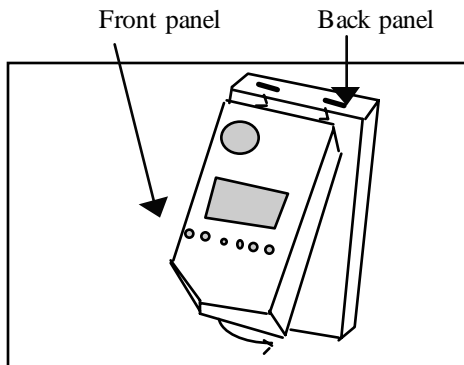
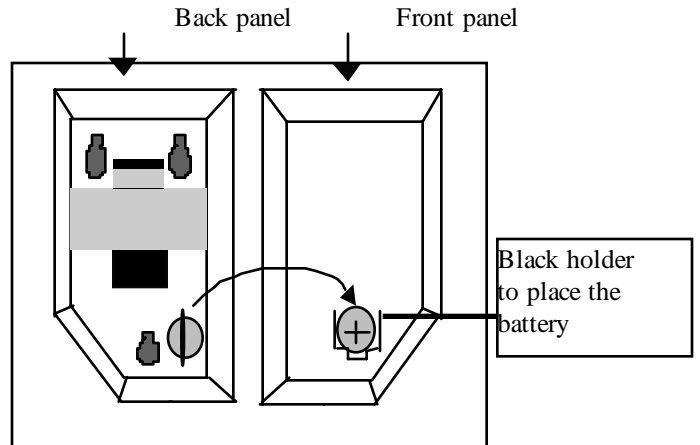

3.11. Re-assemble front and back cover. Connect at top first then at bottom.

3.12. To change jumpers: Disconnect electricity and remove battery and wait 60 seconds

3.13. To enter battery to it's place: connect electricity first and only then enter battery.

Phone line-wiring diagram :

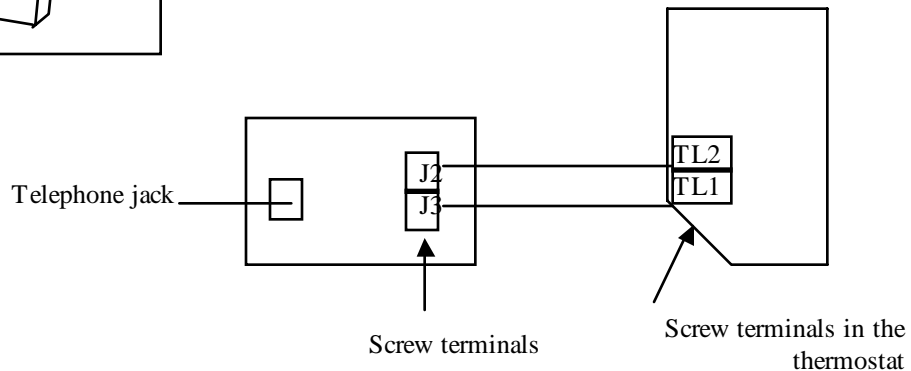

4. Wiring Connections

IF YOU HAVE THE **SUPER** MODEL, MAKE SURE THAT YOU CHOOSE THE RIGHT JUMPER SELECTIONS - PLEASE SEE # 5

- For special types of thermostats the electrical drawing will be added to this manual as an extra page.
- Rc-Rh - If one phase is in use, they must be short - (Default from Factory)

4.1. Connections for 1 heat - 1 Cool - HC11

TL1,TL2 - telephone input
 ⊥ , Q2 - Return Air Sensor SEE # 13
 Q1, - not in use
 AX - Fault input from system
Y1 - Compressor/Cool
 Y2 - *Not in use*
W1 - Heat
 W2 - *Not in use*
G1 - Fan
 Al, Al - low and high temperature alarm dry contact SEE # 12
Rc - Phase for Cool
Rh - Phase for Heat
C - Common

4.2. Connections for 2 Heat - 2 Cool - HC22

TL1,TL2 - telephone input
 ⊥ , Q2 - Return Air Sensor SEE # 13
 Q1, - not in use
 AUX - Fault input from system
Y1 - Compressor/Cool 1
Y2 - Compressor/Cool 2
W1 - Heat 1
W2 - Heat 2
G1 - Fan
 Al, Al - low and high temperature alarm dry contact
 SEE # 12
Rc - Phase for Cool
Rh - Phase for Heat
C - Common

4.4. Connections for Heat Pump 1 stage - HP21

TL1,TL2 - telephone input
 ⊥ , Q2 - Return Air Sensor SEE # 13
 Q1, - not in use
Y1 - Compressor/Cool 1
 Y2 - *Not in use*
W1, (B/O) - Heap pump (to change active cool or heat - See # 5)
W2 - Emergency heat (EMH)
G1 - Fan
 Al, Al - low and high temperature alarm dry contact SEE # 12
Rc - Phase for Cool
Rh - Phase for Heat
C - Common

4.5. Connections for Heat Pump 2 stage - HP32

TL1,TL2 - telephone input
 ⊥ , Q2 - Return Air Sensor SEE # 13

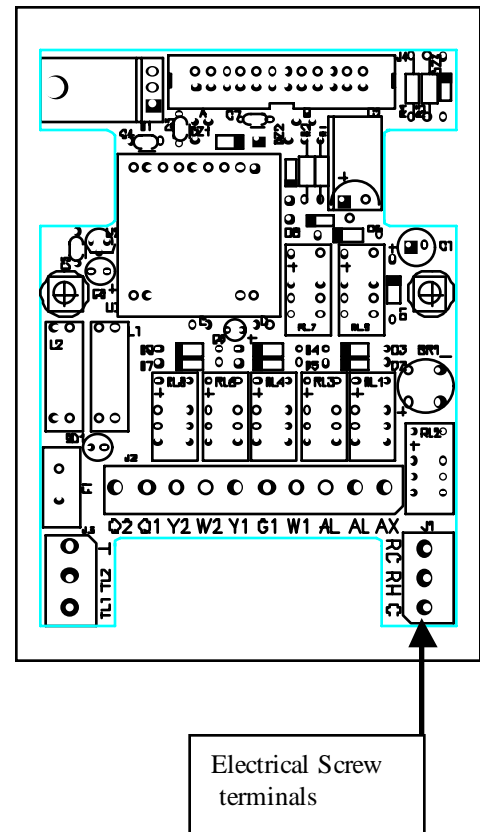

- Q1, - not in use
- AUX - Fault input from system -
- Y1 - Compressor/Cool 1**
- Y2 - Compressor/Cool 2**
- W1, (B/O) - Heat pump (to change active cool or heat - See # 5)**
- W2 - Emergency heat (EMH)**
- G1 - Fan**
- Al, Al - low and high temperature alarm dry contact SEE # 12
- Rc - Phase for Cool**
- Rh - Phase for Heat**
- C - Common**

5. Hardware Jumper Explanations

IMPORTANT - BEFORE MAKING ANY CHANGES IN THE HARDWARE JUMPERS, DISCONNECT ELECTRICITY POWER ON THE MAIN SWITCH.

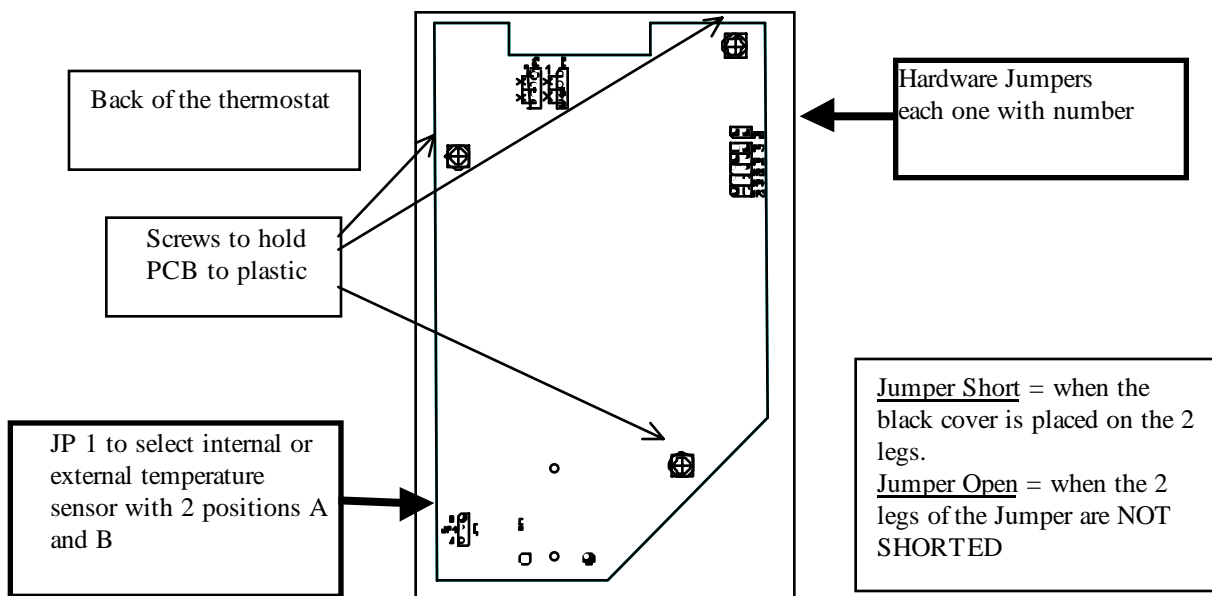

IF you have the SUPER model , Select the configuration of the thermostat.

The options with the jumpers are:

- External sensor
- Relay for compressor
- Clock mode: AM/PM or 24 hours
- Heat pump or non heat pump
- Heat pump active in cool or heat
- Fan mode: electric or oil/gas

This chart will help you select the jumpers:

- HC - (heat, cool) and Fan mode "Oil" or "Electric".
- HP - heat pump and energize in Cool "O" or in Heat "B".

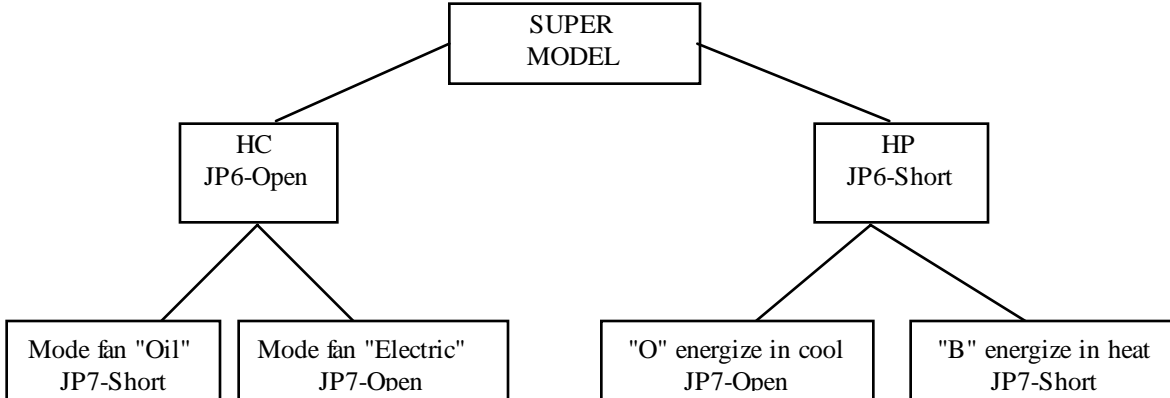

5.1. JP1 - To select external sensor option, it has two positions A and B.

- Position A = Internal Sensor *
- Position B = External Sensor

To connect external sensor – Please see # 13

5.2. JP2 - *Not in use*

5.3. JP3 - Open = Yes 4 minute delay for compressor *

- Short = No time delay for compressor

5.4. JP 4 - Open = Clock mode 24 hours.

- Short = Clock mode AM/PM. *

5.5. JP 5 - *Not in use*

5.6 JP 6 - Open = No heat pump (HC) *

- Short = Yes heat pump (HP)

5.7 JP 7 -IF JP 6 OPEN (Set fan mode in "electric" or "oil/gas")

- Open - Electric mode *
- Short - Oil/Gas mode

Fan mode "electric", fan will be activated or not, depending on the position of the button "AUTO FAN."

Fan mode "oil/gas", this option is used when the heating system is different from the A/C unit. (i.e., furnace)

In this option the fan will work:

- FAN ON position: the fan will work continuously.
- AUTO FAN position: the fan WILL NOT WORK continuously.

5.8 JP 7 -IF JP 6 SHORT (Set heat pump energized in cool or heat)

- Open - Heat pump energized in cool "O". *
- Short - Heat pump energized in heat "B".

* = Default from factory

5.9 How to Change the Jumpers

To change JP 1, 3, 4, 6, 7.

- Disconnect power.
- Change the position of the jumper
- Reconnect power

6. OPERATING MANUAL:

6.1. ON/OFF:

Press ON/OFF button - ON/STBY LED will light and the outputs are now activated (to turn off, press and hold ON/OFF for 3 seconds).

6.2. LCD SCREEN:

The LCD will display two modes in sequence. Clock, Set & Room Temperature.

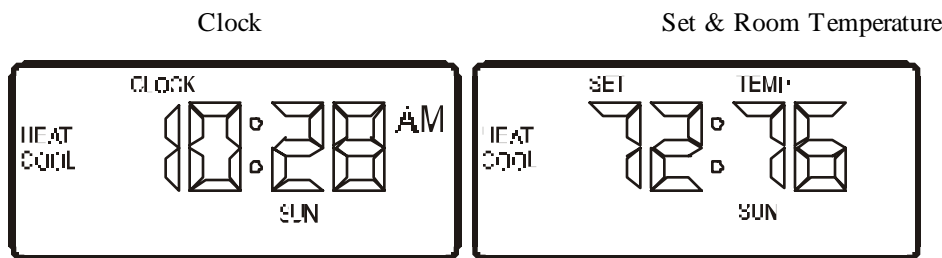

SET BUTTONS

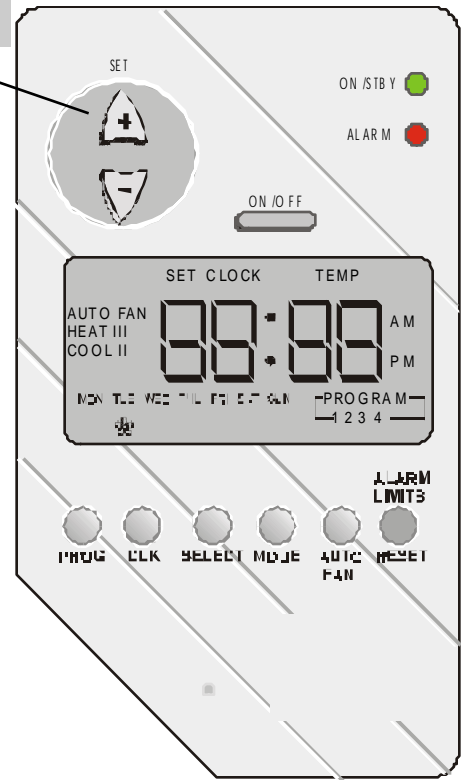

6.3 Real time clock and day:

To set Real time clock and day of the week follow these steps:

- 6.3.1 To adjust the hours: Press clock button; the hour digits will flash. Use the set button press (+) to increase and (-) to decrease the hours.
- 6.3.2 To adjust the minutes: Press clock button; adjust the minutes.
- 6.3.3 To adjust the selected day of the week, press clock again.

The row of week days will flash.

Adjust the day by pressing the set button (eg. if Saturday selected, SAT will show in display, etc).

Press clock again to return to normal display.

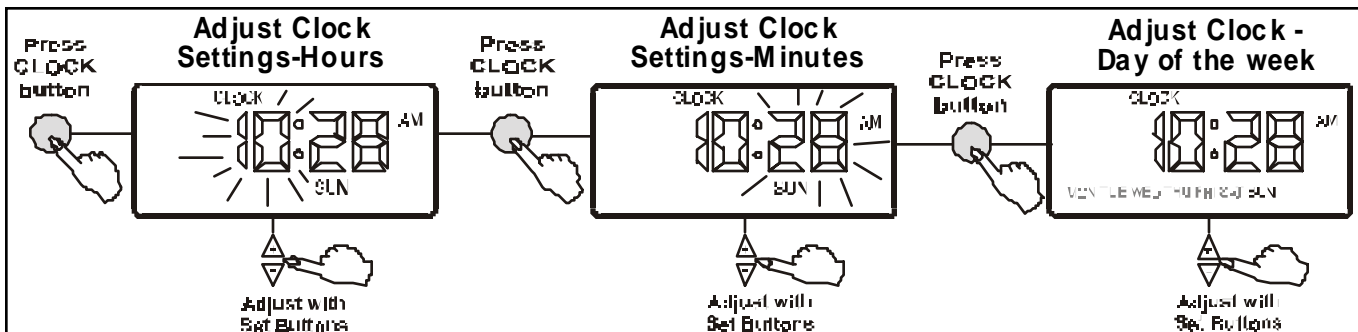

6.4. SELECTING MODES:

Press mode button to switch between the four modes: 1. COOL, 2. HEAT, 3. COOL/HEAT (Auto-change over), 4. FAN ONLY.

6.5. SET TEMPERATURE

Press the SET buttons (+) or (-); the temperature will flash, change with the set buttons (+) or (-).

In auto change mode, press the set buttons (+) or (-), COOL and TEMPERATURE will flash, set your cooling temperature with (+) or (-) buttons.

After three seconds, the HEAT and the TEMPERATURE will flash, set you heating with (+) or (-) buttons.

The HEAT SET must be at least 1 degree less than the COOL SET. The controller will not let you enter the wrong setting. In auto-change mode if the heat set is more than the cool, the system will continually jump from cooling to heating.

7. PROGRAMMING:

The control is a 5-1-1 programmable; weekdays Monday through Friday, Saturday and Sunday have individual programs.

There are four program events per day: 1 (Morning), 2 (Day), 3 (Evening), 4 (Night)

Before programming your thermostat, you should be familiar with the display of the unit.

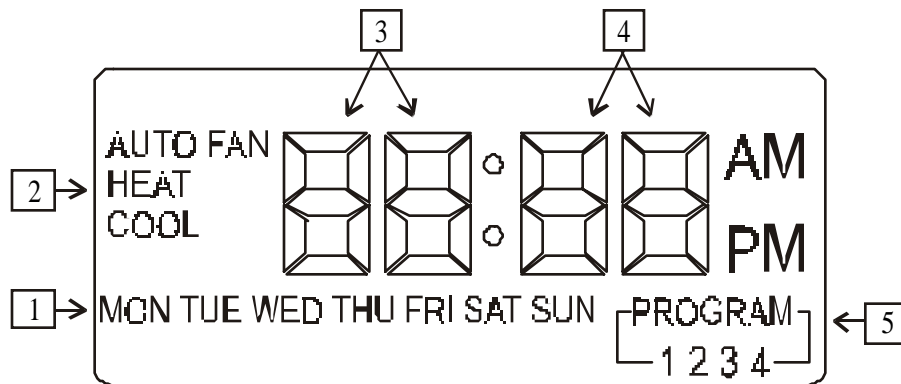

Thermostat Display

1. Days of the week: (when setting the program.). It will display the period that you are setting. Sample; when display shows: MON-TUE-WED-THU-FRI, you are setting the week days program. (The program will repeat on each of these days).
2. MODE, (HEAT/COOL), will be displayed what your are setting the individual temperatures (See # 6.5)
3. Hours digits.
4. Minutes digits.
5. Number of events that you are setting or the current event.

- The following chart will help you make the program.
- We recommend that you fill out the chart BEFORE setting the weekly program.
- On the chart, select a cooling and a heating temperature. This will keep a safe differential between Heat and Cool for auto change over.
- The display will show the program (weekday, Saturday or Sunday) and the event (1, 2, 3, 4)
- During programming, the display will return to normal display if no selections are made in 15 seconds.
- The controller keeps a safe differential of at least 1 degree between Heat set and Cool set.
(Heat is always less than Cool).

Morning

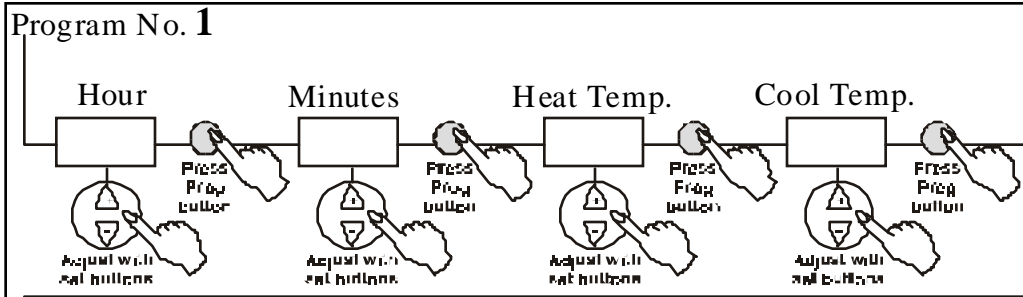

Day

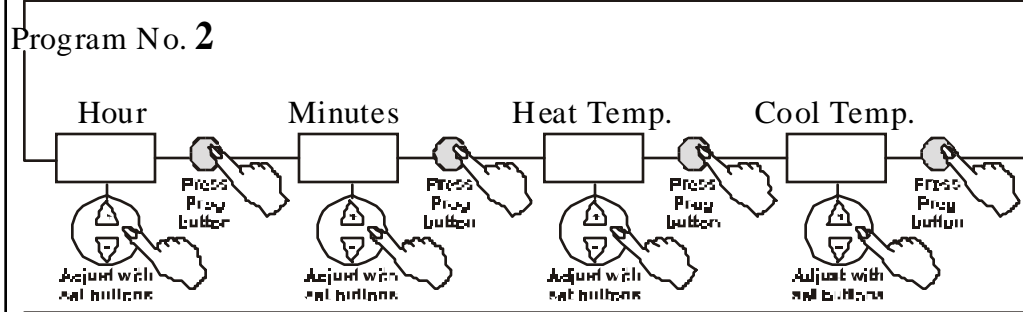

Evening

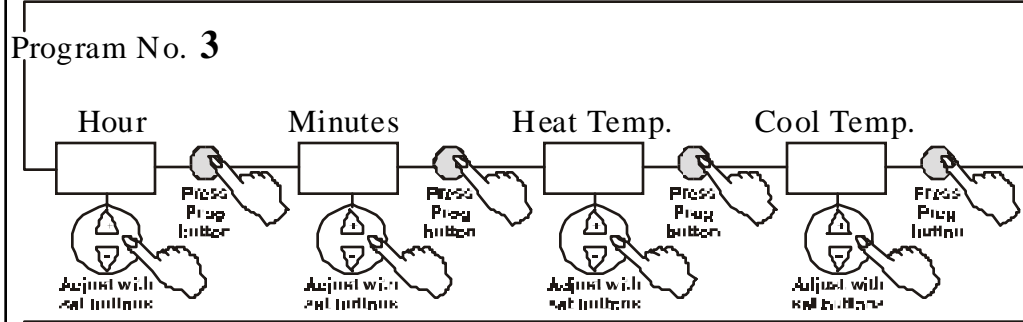

Night

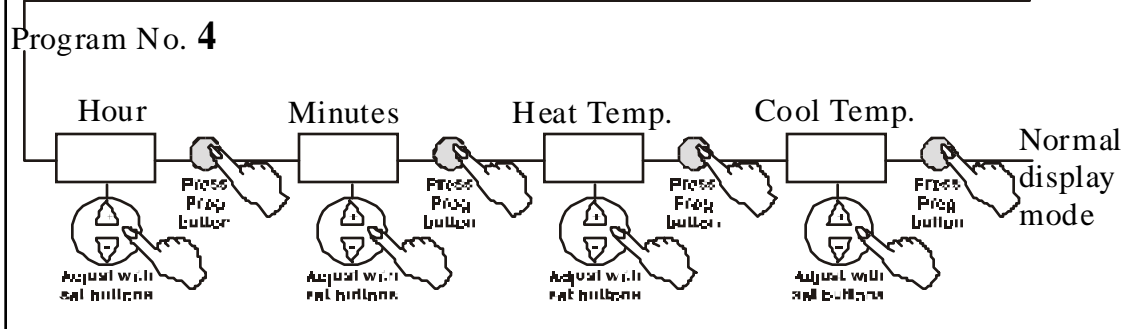

7.1. How to Set the Program

Pressing the PROG button does all Programming selections

7.1.1 Press **Prog** Button: the hours and minutes will flash. This shows that you are entering the **Prog** mode.

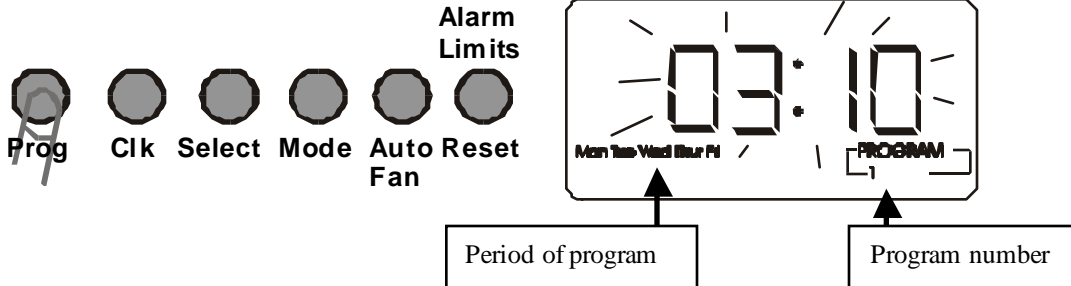

7.1.2 Press **Prog** button, the hours on display will flash, change the hours with the set buttons + to increase - to decrease.

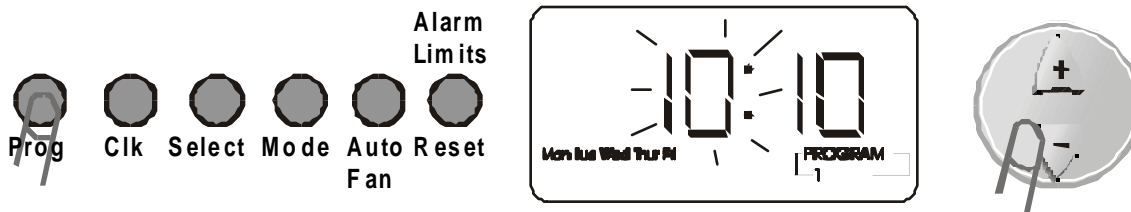

7.1.3 Press **Prog** button again, the minutes on display will flash, change the minutes with the set buttons + to increase - to decrease.



7.1.4 Press **Prog** button again, heat and temperature on display will flash, change the heat set with the set buttons + to increase - to decrease .

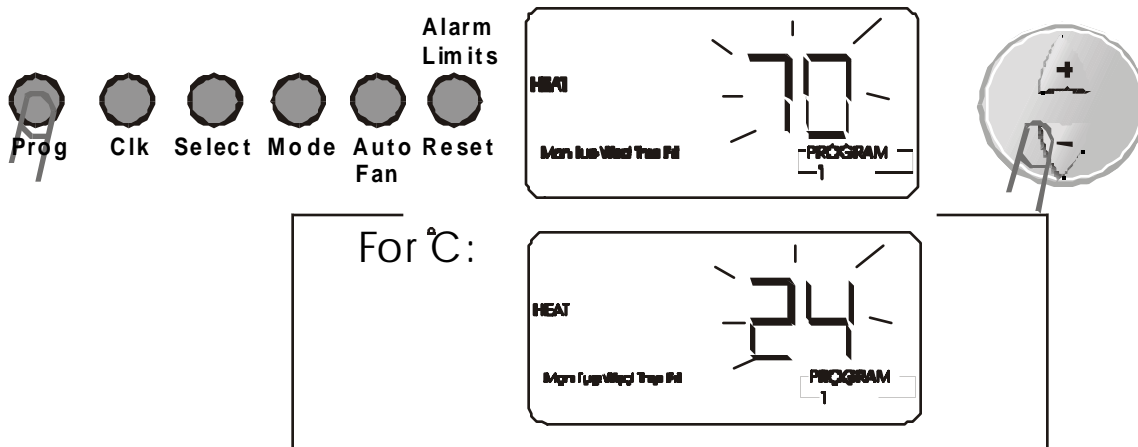

7.1.5 Press **Prog** button again, cool and temperature on display will flash, change the cool set with the set buttons + to increase - to decrease

The controller keeps a safe differential of at least 1 degree between Heat set and Cool set (Heat is always less than Cool).

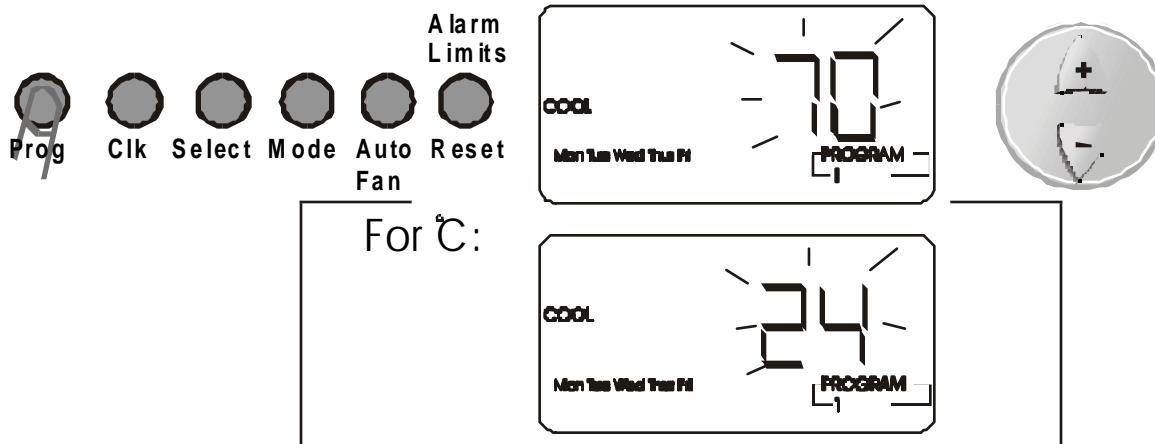

7.1.6: To set the time and temperature for the other programs repeat steps 7.1.2. to 7.1.5.

7.1.7. Press Prog button to return to normal display.

7.2. Weekly Program Mode and Manual Mode.

You can change between Weekly program and Manual program; by pressing and holding (3 seconds) the PROG button in normal display. In weekly program the clock symbol and Program, in brackets, will be displayed. The clock symbol and Program, in brackets, will not be displayed in Manual Mode.

7.3. Review the Prog

You can review the program or change part by entering into the program mode and step quickly through by pressing CLOCK button.

8. FAN/AUTO FAN function:

Press the AUTO FAN button to select AUTO FAN, press again to cancel. In AUTO FAN the fan will only run when calling for heat or cool.

9. OVERRIDE SET TEMPERATURE:

At anytime you may change the temperature by pressing the set buttons. The new temperature will be retained until the next prog start. If the thermostat was in prog mode, then the number of the prog. will disappear until the next prog.



10. UNOCCUPIED MODE (Set back mode)

Unoccupied mode overrides the set point temperature and uses set economy temperatures for heat and cool when you leave home or office for any period of time - vacation, unexpected event - and the system will work in SET BACK mode. (To set temperature for unoccupied mode See # 12.6)

10.1 To set the thermostat to work in Unoccupied Mode.

- Switch on the thermostat
- Press and hold AUTO FAN button (3 sec.) until buzzer "beeps" , EC (Economy) will appear in the display. When returning home (office) press and hold (3 sec.) the AUTO FAN button until buzzer "beeps" and SET TEMP returns to normal.

In Unoccupied Mode, none of the buttons function except **Reset**.

The green LED will light to show that the thermostat is working but the system may be turned off because there is no demand.

11. Reset Button and Alarm Condition (red LED light)

In case the room temperature goes higher or lower than the set alarm (SEE # 12), the alarm LED will flash and the alarm output will be activated .

Press and hold the **Reset** button to clear the alarm.

The alarm will clear by itself if the temperature returns to the normal level.

The alarm output works even if thermostat in "OFF" position.

12. Technician settings

These settings permit changes to the following :

- High temperature limit
- Low temperature limit
- High temperature alarm
- Low temperature alarm
- How to connect external sensor
- How to connect outdoor sensor.
- How to connect extra receiver.

12.1 Enter code for technician

Press **alarm limit** button; the display will show :

Your code is 55. Enter your code by using the set buttons (+,-).

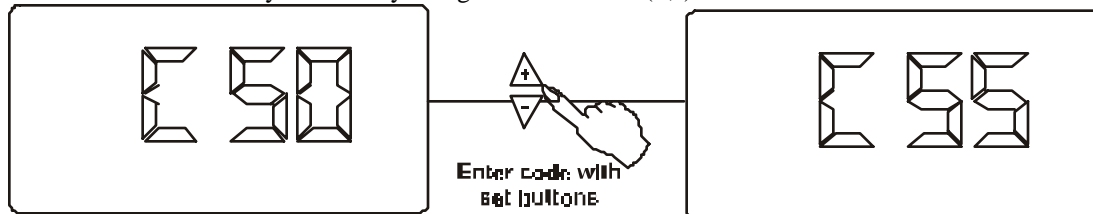

12.2 Set High temperature limit - HL:

Press **alarm limit** button again the display will show:
 Adjust the high limit temperature using the set button (this will limit the Max. range of adjusting set temperature). Range 36°-90°F (4°C-39°C).

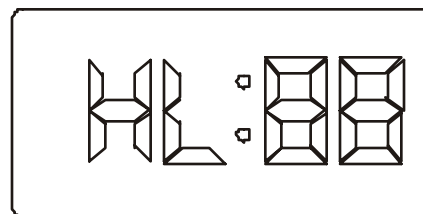

Press Alarm limit again.

12.3 Set Low temperature limit - LL:

Press **ALARM/LIMIT** button again the LCD will show:
 Adjust the low temperature limit using the set button (this will limit the Min. range of adjusting set temperature). Range 35°- 89°F (2°C-38°C). The controller will not allow you to adjust low temperature to be higher than high temperature.

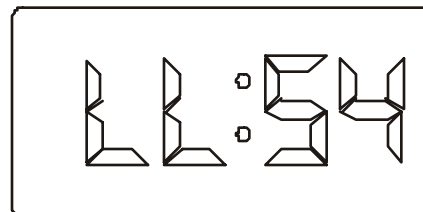

Press Alarm limit again.

12.4 Set High temperature alarm - HA:

Press ALARM/LIMIT button again, the LCD will show:

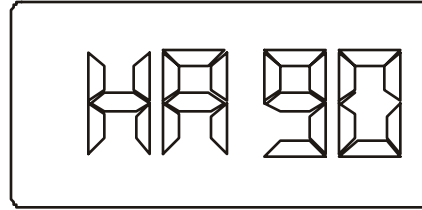

Adjust the temperature using the set button (from 36°-93°F) (4°C-46°C) so when ambient temperature is reached, the alarm activates (red light flashes and dry contact alarm, if available, activates).

Press Alarm limit again.

12.5 Set Low temperature alarm - LA:

Press ALARM/LIMIT again for low temperature, the LCD will show:

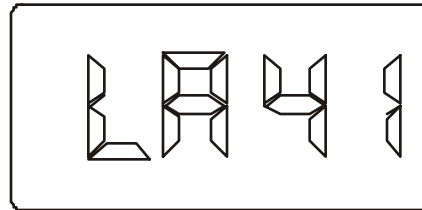

Adjust the temperature you want (35°-92°F) (2°C-44°C).

The unit will not allow you to adjust low temperature alarm to be higher than high temperature alarm.

Press Alarm limit again.

12.6 Press again to set Economy Mode for cooling (your setting for unoccupied mode) 75°-90°F (24°C-31°C).

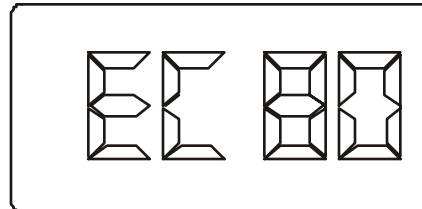

Press again and set Economy Mode for heating (your setting for unoccupied mode) 36°-60°F (5°C-15°C)

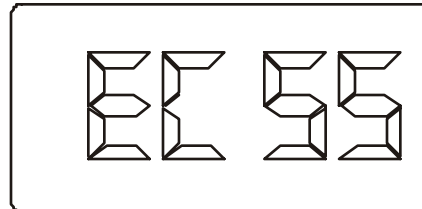

13. Connection of External Sensor

IMPORTANT - THE EXTERNAL SENSOR MUST BE SCI TYPE

N.T.C. Sensor; Temperature ~ Resistance Characteristics

Temp °C	7.2	10.0	12.8	15.6	18.3	21.1	23.9	26.7	29.4	32.2
Temp ° F	45	50	55	60	65	70	75	80	85	90
Res. k	115.8	100.9	88.1	77.1	67.7	59.6	52.5	46.4	41.2	36.6

- 1. Disconnect power to the thermostat 24 Vac.
- 2. Move Jumper 1 to position B. see # 5.9
- 3. Connect the temperature sensor to T1-T1 terminals.
- 4. Reconnect power 24 Vac.

14. To Replace Battery:

Leave controller under 24V open the front cover (see installation instructions) replace battery (3V lithium battery -200MAH)

15. Telephone settings

Press the SELECT button. A four (4) digit code number password will appear 1 2 3 4.

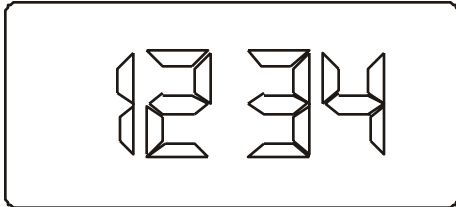

Select a code number which is easy to remember it must be four digits. Press the (+) increase or (-) decrease buttons to change the first number, press SELECT again to change the second number with (+, -) buttons, change the third and fourth number in the same way. Press the SELECT button again, Fn 02 will be displayed.

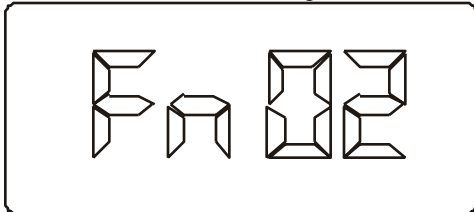

This is the number of rings which you want before the control answers the telephone. It is recommended that you have the telephone ring at least 6 times. This will give you time to answer the telephone and preventing the call from going to the control.

Press SELECT button again, TAD 0 appear in LCD, with (+, -) buttons choose TAD 0 or TAD 1.

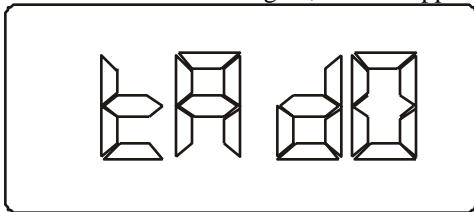

TAD 0 = The unit will work in normal mode.

TAD 1 = This feature allows the unit to be connected with another device on the same telephone line, such as, electric answering machine, fax, etc.

On this feature the numbers of rings of the thermostat and other device **must** be the same.

16. Menu of commands from a telephone to the thermostat

1. Enter your password: 1 2 3 4 # (or any other code you have chosen 4 numbers only) and you will hear the status of the air conditioner:

- a) The temp' in the room is...
- b) The air - conditioner is ON (or OFF)...
- c) The Air-conditioner is in mode (cool, heat, fan, auto change over)...
- c) Set temp' is...

.....

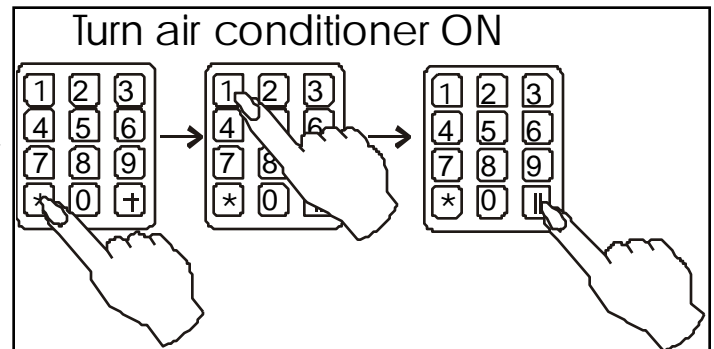

2. Enter your desired command as follows:

- * 1 # : Turn air conditioner ON
- * 2 # : Turn air conditioner OFF
- * 3 # : adjusting desired temperature for cooling :
 press the required temp e.g.: 72 #
- * 4 # : adjusting desired temperature for heating :
 press the required temp e.g.: 71 #

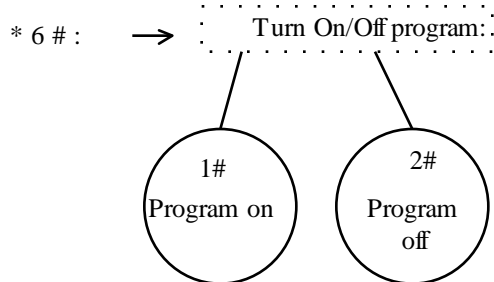
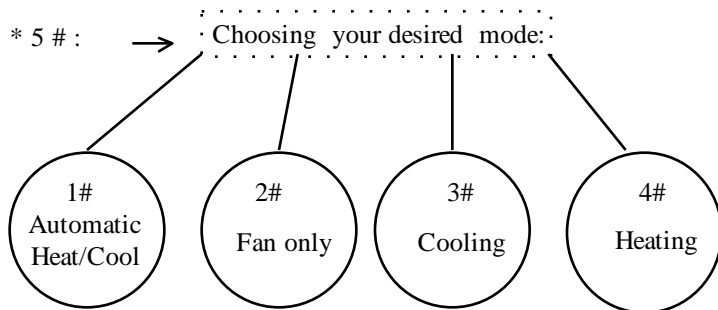

See # 7.2: Weekly Program Mode and Manual Mode

* 0 # : menu of commands

Note: in each step exit or finish

press * 9 #

Important: At the end of each session you should press * 9 # in order to save the new commands.

17. Troubleshooting for Technician

17.1. The display does not light

The unit is not getting 24 Vac

Check the wiring connections, Rh (Phase for heat), Rc(Phase for cool), C(common).



If you are using one phase for cool and heat, check that the short between Rc, Rh and common is tight.

17.2. Temperature in the room (display) dropped to 32°.

The temperature sensor is sensing an OPEN CIRCUIT.

Relace the jumper JMP1, if the temperature returns to normal, there is a problem with the external sensor.

17.3. Temperature in the room (display) rises to 87°

The temperature sensor is sensing a SHORT CIRCUIT.

17.4. Cool stages do not switch on

Check the Rc connection.

17.5. Heat stages do not switch on

Check the Rh connection.

17.6. The unit does not respond to buttons and "EC" appears in the display.

The unit is in Unoccupied Mode.

To return to normal mode , please see #F.

17.7. In heat mode, unit sends cool air.

The Auto Fan is not ON.

SCI - Systems Controls & Instruments can offer a WIDE range of products for the HVAC industry such as :

- Flush Mount Thermostats - Programmable and Non-Programmable.
- HVAC Analyzer that can measure BTU's, for technicians.
- Tamper proof thermostats that can be operated ONLY from the remote control, for public places.
- Thermostat with phone communication; listen to your thermostat from ANYWHERE and change settings. For trial please dial : 1-888-5887113 Password 1,2,3,4,# for Menu *,0,# ...

To obtain more information or technical support :

Tel : 1-800-663-8107.

E-mail : support@scillc.com

Web site: www.scillc.com

Your suggestions or comments regarding these units would be appreciated.

At our web site, you can find technical details regarding the units, as well as , operating manuals, electrical drawings, Etc.

The company reserves the right to change the specifications any time without prior notice.